

LIQUITOL[®]-SU 45

Product Information

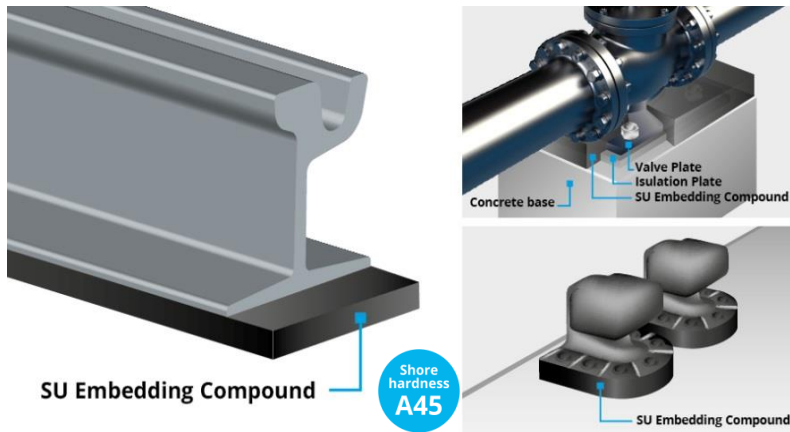

Special advantages:

- Permanently elastic and vibration damping.
- Easy to apply.
- Tested according to VDV notice 6201.
- Chemically and mechanically resistant.
- For numerous fields of application e.g. rails, mooring bollards and fitting foundations (sliding feet).

Elastic hardening, vibration damping pouring compound with low shore hardness for rails, bollards and gate valves.

DEKOTEC GmbH stands for experience, quality and reliability in the field of corrosion prevention and sealing technology. The success is based on the development of the Petrolatum-Tape which was already developed in 1927 as the first product worldwide for passive corrosion prevention of pipelines. We establish and guarantee the highest quality standards with technically trend-setting products. Research, development and production take place exclusively in Germany. Our employees are continuously implementing safe and individual solutions in a personal cooperation with the customer.

Product Description

LIQUITOL[®]-SU 45 consists of a pourable, two-component polyurethane-based system that cures into an elastic material.

LIQUITOL[®]-SU 45 is frost- and road salt-resistant.

Approximate average use: 10 kg/m² per cm material thickness.

Product Usage

LIQUITOL[®]-SU 45 is ideal for use as an elastic and vibration-damping pouring compound for grooved rails and filled section rails as well as for mooring bollards and fitting foundations (sliding feet). The

material is suitable for light railway transportation or when greater deflection is required in the system (e.g. as a pouring compound for machine components).

LIQUITOL[®]-SU 45 is used in pipeline construction as an isolation layer in valve foundations and in port construction as a protective mass for bollards.

Typical Product Properties

LIQUITOL[®]-SU 45 is characterized by the following properties:

- Vibration-reducing
- Chemically and mechanically resistant
- Permanently elastic: in vibration testing, no effects had been observed after 3 million load cycles
- Long-term resistance to temperatures from -20 °C to +70 °C (-4 °F to +158 °F)
- Resistant to water, saline solution (10%), sodium hydroxide solution (5%) and engine oil (SAE 10 W 40)
- Short-term resistance to diesel fuel
- Electrically insulating
- Medium hardness, in accordance with VDV Notice 6201

Typical Technical Material Parameters

Pot life	4-6 min. (approx.)	
Density (cured)	0.72 kg/l (A+B component)	
Shore hardness A	45 ± 5	DIN 53 505
Tear strength	1.6 N/mm ² (approx.)	ISO R 527
Elongation after fracture	170% (approx.)	ISO R 527
Rebound elasticity	40% (approx.)	DIN 53 512
Tear resistance	6.5 N/mm (approx.)	ISO 34-1
Bond strength	1.4 N/mm ² (approx.)	(concrete)

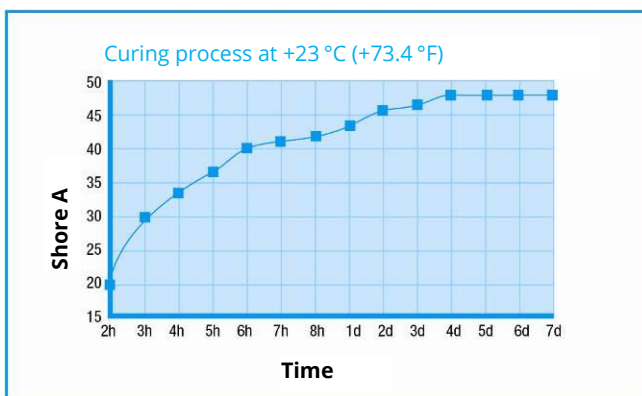

Determination of the secant modulus between 0 and 50 kN using the load-deflection curve.
 Test specimen dimensions (1000 x 188 x 25) mm and emplaced Ri grooved rail with a length of 1000 mm.
 Load rate 6 kN/min. with centred point of loading.

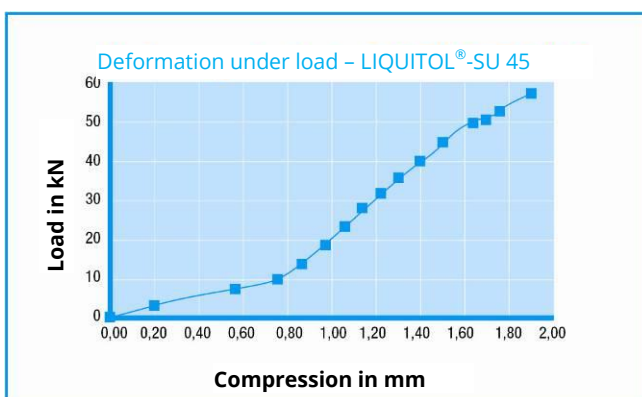

Product Application

Subsurface preparation

The subsurface may be slightly damp. Any oil or grease film present must be removed if permanent joining of the material to the contact area is desired. Dust and other soiling must be removed, as must water, ice or snow. An application of **LIQUITOL®-E Primer** can be used to improve the bond strength across a range of subsurfaces (e.g. steel and concrete).

Preparing the material

Mixing ratio A : B = 100 : 16 (weight), A : B = 100 : 8.8 (volume).

Always ensure that component A has been stirred thoroughly through before working. Following this step, the entire contents of component B are added.

The components must be carefully mixed using a slowly rotating mixer (max. 500 rpm) for about 60–70 seconds. Any material adhering to the sides must be cleaned off and mixed with the rest.

To ensure preparation is rapid and of a high quality, always use a 2-component dosing machine. The air and subsurface temperature should be between +5 °C (+32 °F) and +35 °C (+95 °F).

The material's pot life also depends on the ambient temperature. At room temperature, a pot life of 4–6 minutes can be assumed (incl. time for premixing). The pot life decreases for higher temperatures. The material is tack-free after 2 hours and fully load-bearing after approx. 24 hours.

Ordering Information and Packaging

Product name	Container size	Order number	Packaging units
LIQUITOL®-SU 45	Set 7.55 kg (A+B)	on enquiry	Individual container, 29 sets/pallet
LIQUITOL®-SU 45	Set 160 kg (A+B)	on enquiry	1 tub A comp., 1 can B comp.

Usage 0.72 kg/l (approx.)

Storage

Store unopened product in original pack in a dry place at room temperature.

The material must not be exposed to frost or direct sunlight.

Under these conditions, the material can be stored for at least 12 months from the date of manufacture.

DEKOTEC GmbH

Felderstrasse 24 | 51371 Leverkusen | Germany
 Phone: +49 214 2602-0 | info@dekotec.com
www.dekotec.com

Our product information, application recommendations and other printed publications provide advice to the best of our knowledge and indicate our level of knowledge at the time of printing. The content is not legally binding. Therefore, no liability is assumed for incorrect and missing advice. The applicator is obliged to check the suitability and possibility of application for the intended purpose. Unless otherwise specified, all of the brands named are trademarks, at least registered in Germany, which are protected by law.

Only our general terms and conditions of sale, which you will find at www.dekotec.com, apply. This is a translation from the original German product information. In case of any discrepancy or any dispute arising on the interpretation, the German text of the respective German product information, shall be decisive. The legal relationship shall be governed by German law.